

FARMOWNERS APPLICATION

THIS IS NOT A BINDER

**Incomplete or unsigned Applications
will be returned for completion**

<input type="checkbox"/> New <input type="checkbox"/> Renewal of # _____		DESIRED EFFECTIVE DATE / /		TYPE OF FARM OR RANCH	
APPLICANT			AGENCY NAME Plamp-Keen Agency, Inc.		
DBA			AGENCY CODE 3157001		
MAILING ADDRESS (INCLUDING CITY, STATE, ZIP CODE) _____ _____			AGENT MAILING ADDRESS (INCLUDING CITY, STATE, ZIP CODE) PO Box 5039 Louisville, KY 40255-0039		
PHONE NUMBER ()		FAX NUMBER ()		PHONE NUMBER (800) 626-2494	
EMAIL ADDRESS		SOCIAL SECURITY NUMBER		FAX NUMBER (502) 458-7416	
		EMAIL ADDRESS debi@plampkeen.com			
FARM'S WEBSITE ADDRESS:					
Applicant is: <input type="checkbox"/> Individual <input type="checkbox"/> Partnership <input type="checkbox"/> Corporation <input type="checkbox"/> Other: specify _____					
FEDERAL EIN		NAMES OF ALL PARTNERS OR OFFICERS			
Applicant is: <input type="checkbox"/> Owner Operator <input type="checkbox"/> Absentee Owner <input type="checkbox"/> Other: specify _____					

GENERAL INFORMATION

1. DESCRIBE FARMING OPERATIONS		APPLICANT'S ADDITIONAL OCCUPATION			
2. NUMBER OF YEARS EXPERIENCE IN THIS TYPE OF OPERATION		NUMBER OF YEARS AT THIS LOCATION			
3. HOW LONG HAS THE AGENT KNOWN THE APPLICANT		HAS PROPERTY BEEN INSPECTED <input type="checkbox"/> Yes <input type="checkbox"/> No IF YES, DATE _____			
4. IS OVERALL MAINTENANCE AND CONDITION OF THE GROUNDS, FENCING AND BUILDINGS <input type="checkbox"/> Excellent <input type="checkbox"/> Good <input type="checkbox"/> Fair <input type="checkbox"/> Poor					
5. DESCRIBE ANY BUILDINGS OR FENCES IN FAIR OR POOR CONDITION		HOW OFTEN IS FENCING CHECKED			
6. DO YOU HAVE A ROADSIDE MARKET <input type="checkbox"/> Yes <input type="checkbox"/> No		"PICK YOUR OWN" OPERATIONS <input type="checkbox"/> Yes <input type="checkbox"/> No			
7. IS THERE ANY OTHER BUSINESS BEING CONDUCTED ON THE COVERED LOCATION – IF YES, PLEASE DESCRIBE <input type="checkbox"/> Yes <input type="checkbox"/> No					
8. IS THERE A SWIMMING POOL <input type="checkbox"/> Yes <input type="checkbox"/> No		IF YES, IS IT ENCLOSED BY A FENCE <input type="checkbox"/> Yes <input type="checkbox"/> No		IS IT RESTRICTED TO PRIVATE USE OF RESIDENTS <input type="checkbox"/> Yes <input type="checkbox"/> No	
9. IDENTIFY LIABILITY HAZARDS – CHECK THE BOXES THAT APPLY <input type="checkbox"/> Hunting <input type="checkbox"/> 3-Wheel ATV or ATC <input type="checkbox"/> Trampoline <input type="checkbox"/> Ponds/Fishing <input type="checkbox"/> Airstrip <input type="checkbox"/> Junk Cars <input type="checkbox"/> Other <input type="checkbox"/> Bed & Breakfast <input type="checkbox"/> Daycare <input type="checkbox"/> Overnight Camps					
10. DOES APPLICANT RENT OR LEASE ANY OF THE LAND, BUILDINGS, STABLES TO OTHERS – IF YES, PLEASE EXPLAIN <input type="checkbox"/> Yes <input type="checkbox"/> No					
11. ANY HORSE EXPOSURE? <input type="checkbox"/> YES <input type="checkbox"/> NO IF YES, COMPLETE EQUINE LIABILITY SUPPLEMENT.					
12. ANY DOGS ON THE PROPERTY <input type="checkbox"/> Yes <input type="checkbox"/> No		IF YES, HOW MANY AND WHAT BREED		HAS ANY DOG BITTEN OR CAUSED INJURY TO ANYONE <input type="checkbox"/> Yes <input type="checkbox"/> No	
13. DOES APPLICANT OWN CATTLE <input type="checkbox"/> Yes <input type="checkbox"/> No		SWINE <input type="checkbox"/> Yes <input type="checkbox"/> No		SHEEP <input type="checkbox"/> Yes <input type="checkbox"/> No	
IF YES, NUMBER OF HEAD AND RANGE ACRES		IF YES, NUMBER OF HEAD		IF YES, NUMBER OF HEAD AND RANGE ACRES	
14.a How many farm employees do you have?			14.b. Do you carry workers compensation coverage? <input type="checkbox"/> Yes <input type="checkbox"/> No		
15. HAS ANY COMPANY CANCELLED, DECLINED OR REFUSED TO RENEW SIMILAR COVERAGE – IF YES, PLEASE EXPLAIN <input type="checkbox"/> Yes <input type="checkbox"/> No					

PROPERTY AND LIABILITY -- PREVIOUS 3 YEARS CARRIER INFORMATION

COMPANY	POLICY NUMBER	POLICY PERIOD	PREMIUM	NUMBER OF CLAIMS	LOSSES/ RESERVE
1.					
2.					
3.					

EXPLAIN ANY LOSSES WITHIN PAST THREE YEARS, INCLUDE APPROXIMATE DATES

PROPERTY SECTION

LOC #	# OF ACRES	LEGAL DESCRIPTION OF LOCATIONS TO BE INSURED, INCLUDING COUNTY, STATE, ZIP CODE	USED BY INSURED	MILES FROM FIRE DEPT.	FEET FROM HYDRANT	WIN 10 MILES FROM COAST	BRUSH ZONE
1			<input type="checkbox"/> YES <input type="checkbox"/> NO			<input type="checkbox"/> YES <input type="checkbox"/> NO	<input type="checkbox"/> YES <input type="checkbox"/> NO
2			<input type="checkbox"/> YES <input type="checkbox"/> NO			<input type="checkbox"/> YES <input type="checkbox"/> NO	<input type="checkbox"/> YES <input type="checkbox"/> NO
3			<input type="checkbox"/> YES <input type="checkbox"/> NO			<input type="checkbox"/> YES <input type="checkbox"/> NO	<input type="checkbox"/> YES <input type="checkbox"/> NO
4			<input type="checkbox"/> YES <input type="checkbox"/> NO			<input type="checkbox"/> YES <input type="checkbox"/> NO	<input type="checkbox"/> YES <input type="checkbox"/> NO
5			<input type="checkbox"/> YES <input type="checkbox"/> NO			<input type="checkbox"/> YES <input type="checkbox"/> NO	<input type="checkbox"/> YES <input type="checkbox"/> NO
6			<input type="checkbox"/> YES <input type="checkbox"/> NO			<input type="checkbox"/> YES <input type="checkbox"/> NO	<input type="checkbox"/> YES <input type="checkbox"/> NO

DWELLING INFORMATION

LOC. NO.	DWL. NO.	COVER. A LIMIT	COVERAGE A DWELLING		COVER. B LIMIT	COVER. C LIMIT		COVERAGE C UNSCHED PERS PROP.		COVERAGE D LOSS OF USE LIMIT	TYPE OF CONST.	YEAR BUILT	MOBILE HOME		DED.	CAUSES OF LOSS		
			<input type="checkbox"/> RC <input type="checkbox"/> ACV	<input type="checkbox"/> RC <input type="checkbox"/> ACV		<input type="checkbox"/> RC <input type="checkbox"/> ACV	<input type="checkbox"/> RC <input type="checkbox"/> ACV	<input type="checkbox"/> YES <input type="checkbox"/> NO	<input type="checkbox"/> YES <input type="checkbox"/> NO				BASIC	BROAD		SPECIAL		
			<input type="checkbox"/> RC <input type="checkbox"/> ACV	<input type="checkbox"/> RC <input type="checkbox"/> ACV		<input type="checkbox"/> RC <input type="checkbox"/> ACV	<input type="checkbox"/> RC <input type="checkbox"/> ACV	<input type="checkbox"/> RC <input type="checkbox"/> ACV	<input type="checkbox"/> RC <input type="checkbox"/> ACV				<input type="checkbox"/> YES <input type="checkbox"/> NO	<input type="checkbox"/> YES <input type="checkbox"/> NO		<input type="checkbox"/>	<input type="checkbox"/>	<input type="checkbox"/>
			<input type="checkbox"/> RC <input type="checkbox"/> ACV	<input type="checkbox"/> RC <input type="checkbox"/> ACV		<input type="checkbox"/> RC <input type="checkbox"/> ACV	<input type="checkbox"/> RC <input type="checkbox"/> ACV	<input type="checkbox"/> RC <input type="checkbox"/> ACV	<input type="checkbox"/> RC <input type="checkbox"/> ACV				<input type="checkbox"/> YES <input type="checkbox"/> NO	<input type="checkbox"/> YES <input type="checkbox"/> NO		<input type="checkbox"/>	<input type="checkbox"/>	<input type="checkbox"/>
			<input type="checkbox"/> RC <input type="checkbox"/> ACV	<input type="checkbox"/> RC <input type="checkbox"/> ACV		<input type="checkbox"/> RC <input type="checkbox"/> ACV	<input type="checkbox"/> RC <input type="checkbox"/> ACV	<input type="checkbox"/> RC <input type="checkbox"/> ACV	<input type="checkbox"/> RC <input type="checkbox"/> ACV				<input type="checkbox"/> YES <input type="checkbox"/> NO	<input type="checkbox"/> YES <input type="checkbox"/> NO		<input type="checkbox"/>	<input type="checkbox"/>	<input type="checkbox"/>
			<input type="checkbox"/> RC <input type="checkbox"/> ACV	<input type="checkbox"/> RC <input type="checkbox"/> ACV		<input type="checkbox"/> RC <input type="checkbox"/> ACV	<input type="checkbox"/> RC <input type="checkbox"/> ACV	<input type="checkbox"/> RC <input type="checkbox"/> ACV	<input type="checkbox"/> RC <input type="checkbox"/> ACV				<input type="checkbox"/> YES <input type="checkbox"/> NO	<input type="checkbox"/> YES <input type="checkbox"/> NO		<input type="checkbox"/>	<input type="checkbox"/>	<input type="checkbox"/>
			<input type="checkbox"/> RC <input type="checkbox"/> ACV	<input type="checkbox"/> RC <input type="checkbox"/> ACV		<input type="checkbox"/> RC <input type="checkbox"/> ACV	<input type="checkbox"/> RC <input type="checkbox"/> ACV	<input type="checkbox"/> RC <input type="checkbox"/> ACV	<input type="checkbox"/> RC <input type="checkbox"/> ACV				<input type="checkbox"/> YES <input type="checkbox"/> NO	<input type="checkbox"/> YES <input type="checkbox"/> NO		<input type="checkbox"/>	<input type="checkbox"/>	<input type="checkbox"/>
			<input type="checkbox"/> RC <input type="checkbox"/> ACV	<input type="checkbox"/> RC <input type="checkbox"/> ACV		<input type="checkbox"/> RC <input type="checkbox"/> ACV	<input type="checkbox"/> RC <input type="checkbox"/> ACV	<input type="checkbox"/> RC <input type="checkbox"/> ACV	<input type="checkbox"/> RC <input type="checkbox"/> ACV				<input type="checkbox"/> YES <input type="checkbox"/> NO	<input type="checkbox"/> YES <input type="checkbox"/> NO		<input type="checkbox"/>	<input type="checkbox"/>	<input type="checkbox"/>

MOBILE HOME SECTION

MAKE	SERIAL NUMBER(S)	SOLID FOUNDATION <input type="checkbox"/> YES <input type="checkbox"/> NO	TIE DOWN <input type="checkbox"/> YES <input type="checkbox"/> NO	SKIRTED <input type="checkbox"/> YES <input type="checkbox"/> NO
MAKE	SERIAL NUMBER(S)	SOLID FOUNDATION <input type="checkbox"/> YES <input type="checkbox"/> NO	TIE DOWN <input type="checkbox"/> YES <input type="checkbox"/> NO	SKIRTED <input type="checkbox"/> YES <input type="checkbox"/> NO

NOTE: Coverage B unavailable in California. Additional Structures can be covered under Coverage E.

DWG. NO.	PRIMARY RESIDENCE Y/N	OCCUP. SEASONAL Y/N	TENANT Y/N	EMPL. Y/N	SQ. FT. GRND FLOOR	LOCAL ALARM Y/N	CENTRAL STATION Y/N	SMOKE/HEAT DET. Y/N	TYPE OF HEAT	THERMO. CONTROL. Y/N	WOODSTOVE/FIREPLACE Y/N*	NR. WATER SOURCE Y/N	YEAR UPDATE		
													PLUMBING	ELEC-TRICAL	ROOF
1															
2											*Complete				
3											Woodstove				
4											Suppl.				
5															
6															
7															

FIRST MORTGAGEE	MAILING ADDRESS INCLUDING ZIP CODE	LOAN NUMBER
SECOND MORTGAGEE	MAILING ADDRESS INCLUDING ZIP CODE	LOAN NUMBER
LOSS PAYEE	MAILING ADDRESS INCLUDING ZIP CODE	

ADDITIONAL PERSONAL PROPERTY COVERAGE

SCHEDULED PROPERTY	TOTAL LIMIT	SCHEDULED PROPERTY	TOTAL LIMIT
Jewelry	\$	Fine Arts	\$
Furs	\$	Other	\$
Silverware	\$	(A complete schedule and current appraisals (within 3 years) on any item over \$1,500 must be provided before coverage can be bound.)	

SCHEDULE OF COMPUTER EQUIPMENT

DEDUCTIBLE:

HARDWARE LIMIT	MAKE	DESCRIPTION	SERIAL NUMBER
SOFTWARE LIMIT			

LIABILITY SECTION**LIMITS OF LIABILITY CHECK ONE**
 \$500,000 \$1,000,000 Other \$

 \$5,000 Medical Payments to Others Included.
 \$50,000 Fire Legal Liability. Inquire about the
 availability of higher limits and options.
LIABILITY FORMS
 Farm Liability **OR** Commercial Farm/Stable With Personal Liability: Included Excluded

Umbrella Coverage is available in most states. Please contact your agent for information and an application.

ADDITIONAL INSURED (SUBJECT TO COMPANY APPROVAL)

NAME	ADDRESS	INTEREST	REASON

ADDITIONAL RESIDENCE PREMISES OCCUPIED BY INSURED (LIABILITY ONLY)**WATERCRAFT LIABILITY (GL-82) MVR Required**

COMPLETE DESCRIPTION	MAKE	SERIAL #	LENGTH	H.P.	M.P.H.

SNOWMOBILE LIABILITY (GL-83) MVR Required

COMPLETE DESCRIPTION	MAKE OR MODEL	SERIAL #

OFFICE, PROFESSIONAL, PRIVATE SCHOOL, STUDIO OCCUPANCY (GL-80)

DESCRIPTION OF BUSINESS	LOCATION

INCIDENTAL BUSINESS PURSUITS – EXCLUDING PRODUCTS AND COMPLETED OPERATIONS (GL-90)

NAME OF INSURED(S)	BUSINESS DESCRIPTION	ESTIMATED GROSS ANNUAL RECEIPTS

ARE YOU ENGAGED IN CUSTOM FARM WORK (GL-75)
 Yes No

IF YES, PROVIDE ESTIMATE OF ANNUAL RECEIPTS
 \$

DO YOU CARRY WORKERS COMPENSATION COVERAGE
 Yes No

CARRIER POLICY NUMBER

FAIR CREDIT REPORTING ACT NOTICE

A consumer report may be requested by the insurer to which this application is submitted. Subsequent consumer reports may be requested in connection with an update or renewal or extension of the insurance for which this application is made. The applicant, upon request, will be informed whether or not a consumer report was requested, and if such report was requested, informed of the name and address of the consumer reporting agency that furnished the report.

STANDARD FRAUD WARNING

Any person who knowingly and with intent to defraud any insurance company or other person files an application for insurance or statement of claim containing any materially false information or conceals, for the purpose of misleading, information concerning any fact material thereto, commits a fraudulent insurance act, which is a crime, and may subject such person to criminal and substantial civil penalties. (This wording does not apply in Oregon.)

- FLORIDA: Any person who knowingly and with intent to injure, defraud or deceive any insurer files a statement of claim or an application containing any false, incomplete or misleading information is guilty of a felony of the third degree.
- NEW JERSEY: Any person who includes any false or misleading information on an application for an insurance policy is guilty of insurance fraud and is subject to criminal and civil penalties.
- VIRGINIA: It is a crime to knowingly provide false, incomplete or misleading information to an insurance company for the purpose of defrauding the company. Penalties include imprisonment, fines and denial of insurance benefits.
- WASHINGTON D.C.: WARNING: It is a crime to provide false or misleading information to an insurer for the purpose of defrauding the insurer or any other person. Penalties include imprisonment and/or fines. In addition, an insurer may deny insurance benefits if false information materially related to a claim was provided by the applicant.

The undersigned hereby applies for insurance coverage as set forth in the application and affirms that the statements and representations made are to the best of his/her knowledge true.

DATE / /	APPLICANT'S SIGNATURE (REQUIRED) X	DATE OF LAST INSPECTION / /	<input type="checkbox"/> I have NOT seen the property. <input type="checkbox"/> I have seen the property.
DATE / /	AGENT'S SIGNATURE (REQUIRED) X		

The following Supplements are attached (please check):

- Equine Liability Supplement
- Coverage G – Blanket Farm Personal Property Supplement
- Fireplace, Wood Burning Stove Supplement
- Collapse Coverage Supplement

**CHECK EACH COVERAGE DESIRED (ALL COVERAGE MAY NOT BE AVAILABLE IN ALL STATES
THIS IS NOT A COMPLETE LIST)**

ENDORSE- MENT #	COVERAGE OPTIONS	ENDORSE- MENT #	COVERAGE OPTIONS
<input type="checkbox"/> FO-15	Actual Cash Value	<input type="checkbox"/> FO-346	4-H and F.F.A. Animals
<input type="checkbox"/> FO-25	Consent to Move Mobile Home	<input type="checkbox"/> FO-349	Suffocation of Livestock
<input type="checkbox"/> FO-26	Collision or Upset	<input type="checkbox"/> FO-350	Debris Removal – Coverages E and F
<input type="checkbox"/> FO-27	Secured Party's Interest – Additional Coverage	<input type="checkbox"/> FO-352	Peak Season Inventory – Farm Personal Property
<input type="checkbox"/> FO-30	Incidental Property Coverages – Higher Limits	<input type="checkbox"/> FO-354	Earthquake – Coverages E, F and G
<input type="checkbox"/> FO-41	Additional Insureds (Property)	<input type="checkbox"/> FO-356	Added Animal Perils
<input type="checkbox"/> FO-48	Related Private Structures	<input type="checkbox"/> FO-360	Farm Machinery
<input type="checkbox"/> FO-54	Earthquake	<input type="checkbox"/> FO-361	Property in Transit – Coverages F and G
<input type="checkbox"/> FO-55	Replacement Value	<input type="checkbox"/> FO-362	Special Form Coverage – Farm Barns, Buildings, and Structures
<input type="checkbox"/> FO-60	Debris Removal	<input type="checkbox"/> FO-363	Repair or Rebuilding Requirement
<input type="checkbox"/> FO-61	Scheduled Personal Property	<input type="checkbox"/> FO-364	Replacement Cost Provision for Well Pumps
<input type="checkbox"/> FO-65	Coverage C – Higher Limit of Liability on Certain Property	<input type="checkbox"/> FO-6 Policy Form	Farm Extra Expense \$_____ Limit
<input type="checkbox"/> FO-68	Scheduled Glass	<input type="checkbox"/> GL-9	Personal Liability Coverage
<input type="checkbox"/> FO-69	Business Property – Business Occupancy on the Insured Premises	<input type="checkbox"/> GL-40	Structures Rented to Others
<input type="checkbox"/> FO-70	Ordinance or Law	<input type="checkbox"/> GL-70	Additional Insured – Persons or Organizations
<input type="checkbox"/> FO-75	Amendment of Vacancy or Unoccupancy	<input type="checkbox"/> GL-71	Additional Insured – Partners or Co-owners
<input type="checkbox"/> FO-123	Pollutant Clean Up and Removal	<input type="checkbox"/> GL-72	Additional Insureds
<input type="checkbox"/> FO-125	Dwelling Under Construction – Theft	<input type="checkbox"/> GL-73	Additional Residences or Farms – Rented to Others
<input type="checkbox"/> FO-170	Computers	<input type="checkbox"/> GL-74	Business Activities
<input type="checkbox"/> FO-178	Insurance By More Than One Company	<input type="checkbox"/> GL-75	Custom Farm Work
<input type="checkbox"/> FO-184	Automatic Adjustment of Limits	<input type="checkbox"/> GL-76	Employer's Liability – Farm Employees
<input type="checkbox"/> FO-200	Replacement Cost Terms – Mobile Homes	<input type="checkbox"/> GL-78	Fruit or Vegetable Picking – By Public
<input type="checkbox"/> FO-208	Water Damage – Sewers, Drains and Sumps	<input type="checkbox"/> GL-80	Office, Professional, Private School, or Studio Occupancy
<input type="checkbox"/> FO-216	Premises Alarm or Fire Protection System	<input type="checkbox"/> GL-81	Personal Injury (with GL-2, GL-9 only)
<input type="checkbox"/> FO-255	Repair Cost Terms	<input type="checkbox"/> GL-82	Watercraft
<input type="checkbox"/> FO-256	Modified Replacement Cost Terms	<input type="checkbox"/> GL-83	Snowmobile
<input type="checkbox"/> FO-257	Ordinance or Law – Farm Barns, Buildings and Structures	<input type="checkbox"/> GL-84	Care Provided for Others
<input type="checkbox"/> FO-307	Sprinkler Leakage	<input type="checkbox"/> GL-90	Incidental Business Pursuits
<input type="checkbox"/> FO-323	Weight of Ice, Snow or Sleet	<input type="checkbox"/> GL-95	Products Aggregate Limits
<input type="checkbox"/> FO-324	Winter Perils – Livestock	<input type="checkbox"/> GL-108	Additional Insureds
<input type="checkbox"/> FO-330	Incidental Property Coverages – Higher Limits	<input type="checkbox"/> GL-615	Exclusion of Products/Completed Work Coverage
<input type="checkbox"/> FO-340	Limited Perils – Coverages E, F and G	<input type="checkbox"/> GL-872	Farm Employers Liability Coverage (with GL-610 only)
<input type="checkbox"/> FO-341	Replacement Cost Terms – Farm Barns, Buildings and Structures	<input type="checkbox"/> GL-904	Personal and Advertising Injury Liability Coverage (with GL-610 only)
<input type="checkbox"/> FO-345	Theft of Building Materials – Farm Barns, Buildings and Structures	<input type="checkbox"/> AD9182EM	Horse Boarding Operations

EQUINE LIABILITY SUPPLEMENT

THIS SUPPLEMENT FORMS PART OF OUR FARMOWNER APPLICATION

(Umbrella coverage is available in most states. Please contact your agent for information and an application.)

SECTION I SUMMARY OF HORSES – AT PEAK SEASON

ACCOUNT FOR EACH ANIMAL BELOW ONLY ONCE, BASED ON ITS PRIMARY USE

Horses Owned/Leased/Used by Insured	Number	Horses Non-Owned by Insured	Number
1. a. Owned horses used for instruction.....	_____	1. Boarding/pasturing	_____
b. Boarded horses used for instruction to others	_____	2. Show training	_____
2. Show and/or pleasure	_____	3. Racing and/or training to race	_____
3. Racing and/or training to race	_____	4. Breeding (Mares _____, Stallions _____)	_____
4. Breeding (Mares _____, Stallions _____)	_____	5. Foals/weanlings	_____
5. Foals/weanlings	_____	6. Retired and/or lay-ups	_____
6. Retired and/or lay-ups	_____	7. Consignment for sale (Breed _____)	_____
7. For sale (Breed _____)	_____	8. Other (Describe _____)	_____
8. Other (Describe _____)	_____		
All Owned Horses Must be Declared..... Total (Lines 1-8) _____		Total (Lines 1-8) _____	
9. Number of carts, buggies, carriages, etc.	_____	9. Total number of stalls on your premises	_____
Describe use: _____		10. What is the maximum number of horses, owned and non-owned, that can be kept in your premises	_____

SECTION II HORSES NON-OWNED BOARDING, BREEDING, TRAINING, RACING

CHECK IF NO EXPOSURE

1. TOTAL # OF STALLS	MAXIMUM # BOARDED	PASTURED	MONTHLY BOARDING RATE \$	ANNUAL GROSS \$
2. TRAINING PLEASURE & SHOW – MAXIMUM # OF NON-OWNED HORSES IN TRAINING			MONTHLY TRAINING RATE \$	ANNUAL GROSS \$
3. BREEDING - # OF NON-OWNED STALLIONS	BREED		MAX # OF OUTSIDE MARES	ARE MARES KEPT ON PREMISES UNTIL FOALING <input type="checkbox"/> Yes <input type="checkbox"/> No
4. RACE HORSES – WHAT BREEDS	HOW MANY DO YOU TRAIN FOR OTHERS		PAYROLL \$	WHAT STATES DO YOU RACE IN

ARE YOU ACTIVELY INVOLVED IN THE RACING/TRAINING OF YOUR OWN RACE HORSES

Yes No

SECTION III SALES HORSE, FOOD, CLOTHING, TACK, FEED, HORSESHOEING

CHECK IF NO EXPOSURE

1. DO YOU SELL HORSES <input type="checkbox"/> Yes <input type="checkbox"/> No	WHAT BREEDS	HOW MANY PER YEAR	GROSS ANNUAL RECEIPTS \$
2. IS BUYER ALLOWED TO TEST RIDE <input type="checkbox"/> Yes <input type="checkbox"/> No	IF YES <input type="checkbox"/> In arena <input type="checkbox"/> In open field	DO YOU SELL FROM YOUR OWN PREMISES <input type="checkbox"/> Yes <input type="checkbox"/> No	
3. EXPLAIN ANY OTHER METHOD OF SALES			
4. DO YOU SELL FOOD OR HAVE A SNACK BAR (LIQUOR LIABILITY NOT COVERED) <input type="checkbox"/> Yes <input type="checkbox"/> No			GROSS RECEIPTS \$
5. DO YOU SELL TACK AND/OR CLOTHING – IF YES, USED OR NEW <input type="checkbox"/> Yes <input type="checkbox"/> No <input type="checkbox"/> Used <input type="checkbox"/> New			GROSS RECEIPTS \$
6. DO YOU SELL HAY OR FEED <input type="checkbox"/> Yes <input type="checkbox"/> No			GROSS RECEIPTS \$
7. DO YOU MIX FEED FOR SALE/CONSUMPTION <input type="checkbox"/> Yes <input type="checkbox"/> No			
8. DO YOU REPAIR RIDING EQUIPMENT FOR OTHERS <input type="checkbox"/> Yes <input type="checkbox"/> No			
9. DO YOU PERFORM ANY TYPE OF FARRIER SERVICES (INJURY TO HORSE NOT COVERED) <input type="checkbox"/> Yes <input type="checkbox"/> No			If on premises only this coverage can be added to this policy.
ARE SERVICES ON PREMISE ONLY <input type="checkbox"/> Yes <input type="checkbox"/> No			GROSS RECEIPTS \$

NOTE: Products liability for any and all exposures involving sale of horses or other livestock, repair of tack, sale of feed if mixed or prepared by the insured is excluded from coverage.

SECTION IV EQUESTRIAN SCHOOLS – RIDING INSTRUCTION – CLINICS CHECK IF NO EXPOSURE

1. IS INSTRUCTION PROVIDED BY <input type="checkbox"/> You <input type="checkbox"/> An Independent Instructor		If an independent instructor/trainer is used, complete Section V.		ARE YOU A CERTIFIED INSTRUCTOR <input type="checkbox"/> Yes <input type="checkbox"/> No	
2. DESCRIBE TYPE OF SAFETY GEAR REQUIRED					
3. DO YOU PROVIDE RIDING FOR THE HANDICAPPED <input type="checkbox"/> Yes <input type="checkbox"/> No			# OF HORSES AVAILABLE FOR HANDICAPPED		GROSS ANNUAL RECEIPTS \$
NON-PROFIT <input type="checkbox"/> Yes <input type="checkbox"/> No			RATIO OF INSTRUCTORS TO STUDENTS		
ARE SIDEWALKERS USED <input type="checkbox"/> Yes <input type="checkbox"/> No			VOLUNTEER COVERAGE REQUESTED <input type="checkbox"/> Yes <input type="checkbox"/> No		
4. MAXIMUM NUMBER OF SCHOOL HORSES AVAILABLE			MAXIMUM NUMBER USED AT ANY ONE TIME		GROSS ANNUAL RECEIPTS \$
5. ARE STALLIONS USED FOR INSTRUCTION <input type="checkbox"/> Yes <input type="checkbox"/> No			IF SO, INDICATE THE LEVEL OF THE RIDER AND AGE		
6. DO YOU GIVE INSTRUCTION TO STUDENTS ON THEIR OWN HORSES <input type="checkbox"/> Yes <input type="checkbox"/> No			IF SO, ADVISE AVERAGE NUMBER OF LESSONS PER WEEK		ANNUAL GROSS RECEIPTS \$
7. DO YOU TEACH <input type="checkbox"/> English <input type="checkbox"/> Jumping <input type="checkbox"/> Saddle Seat <input type="checkbox"/> Western <input type="checkbox"/> Dressage <input type="checkbox"/> Other:					
8. IS THERE ANY PERIOD OF THE YEAR DURING WHICH YOU DO NOT GIVE INSTRUCTIONS – IF SO, GIVE DATES CLOSED <input type="checkbox"/> Yes <input type="checkbox"/> No					
9. DO YOU ATTEND OFF-PREMISES SHOWS WITH YOUR STUDENTS <input type="checkbox"/> Yes <input type="checkbox"/> No			Injuries to horses and students being transported are not covered.		HOW MANY TIMES PER YEAR \$
10. DO YOU HOLD CLINICS FOR NON-STUDENTS <input type="checkbox"/> Yes <input type="checkbox"/> No		HOW MANY DAYS		AVERAGE ATTENDANCE	
				RECEIPTS EARNED \$	
11. DO YOU OPERATE A DAY CAMP <input type="checkbox"/> Yes <input type="checkbox"/> No		OVERNIGHT CAMP <input type="checkbox"/> Yes <input type="checkbox"/> No		DO YOU PROVIDE FOOD <input type="checkbox"/> Yes <input type="checkbox"/> No	
				GROSS RECEIPTS FOR CAMP \$	
12. DESCRIBE ALL ACTIVITIES OFFERED AT CAMPS OTHER THAN RIDING INSTRUCTIONS					

SECTION V INDEPENDENT INSTRUCTORS / TRAINERS CHECK IF NO EXPOSURE

1. DO INDEPENDENT TRAINERS OR INSTRUCTORS OPERATE ON YOUR PREMISES – IF SO, HOW MANY <input type="checkbox"/> Yes <input type="checkbox"/> No		DO THEY CARRY THEIR OWN INSURANCE++ <input type="checkbox"/> Yes <input type="checkbox"/> No	
<p>++ If so, we will require a copy of a Certificate of Insurance for each insured for coverage with limits equal to those you carry. We will also require that they name you as an additional insured under their policy. If the independent instructors or trainers DO NOT carry their own insurance, they will be added as an insured for an additional charge if eligible. Coverage is limited to on-premises only and to off-premise shows with horses and/or riders in training.</p>			
PROVIDE NAMES OF INDEPENDENT INSTRUCTORS OR TRAINERS AND ADDRESSES (MUST BE 18 YEARS OF AGE OR OLDER)			

INDEPENDENTS COVERED ON THIS POLICY MUST USE A RELEASE – ATTACH COPY(IES)			
2. HOW MANY HORSES ARE PROVIDED FOR LESSONS BY INDEPENDENT INSTRUCTORS		GROSS RECEIPTS \$	GROSS RECEIPTS FOR INSTR. TO STUDENTS ON THEIR OWN HORSES \$
3. HOW MANY OF YOUR BOARDED HORSES ARE BEING TRAINED BY INDEPENDENT TRAINERS			OR TRAINED UNDER YOUR NAME

SECTION VI PONY RIDES/SADDLE ANIMALS FOR HIRE/HOURLY OR DAILY RENTALS/TRAIL RIDES/LEASING/PACK TRIPS CHECK IF NO EXPOSURE

1. # OF ANIMALS AVAILABLE FOR RENTAL OR TRAIL RIDES		GROSS RECEIPTS FOR RENTALS \$	GROSS RECEIPTS FOR TRAIL RIDES \$	DO YOU CONDUCT PACK TRIPS <input type="checkbox"/> Yes <input type="checkbox"/> No
2. PONY RIDES/PARTIES – NUMBER OF PONIES		GROSS RECEIPTS \$	DO YOU USE SIDEWALKERS <input type="checkbox"/> Yes <input type="checkbox"/> No	
3. DO YOU RENT OR LEASE HORSES OR PONIES TO CAMPS/RESORTS OR INDIVIDUALS – IF SO, HOW MANY – PLEASE EXPLAIN <input type="checkbox"/> Yes <input type="checkbox"/> No				

SECTION VII RIDES, HORSE SHOWS AND MISCELLANEOUS ACTIVITIES

CHECK IF NO EXPOSURE

1. RIDES	# OF PASSENGERS	GROSS RECEIPTS	# OF WAGONS	# OF HORSES	# OF MOTOR VEH	# OF TRIPS	ON OR OFF PREMISES
<input type="checkbox"/> Hay <input type="checkbox"/> Sleigh <input type="checkbox"/> Carriage		\$					

2. SHOWS

INDEPENDENT VENDORS ARE NOT COVERED

ARE THESE SHOWS RECOGNIZED BY THE AMERICAN HORSE SHOW ASSOCIATION

Yes No

DO YOU MANAGE ANY SHOWS OPEN TO BOARDERS OR NON-STUDENTS

Yes No

SHOWS	# OF PARTICIPANTS	GROSS RECEIPTS ALL SHOWS	MAX # OF SPECTATORS PER DAY	TOTAL # OF SHOW DAYS	SHOW DATES
Shows on Premises		\$			
Rodeos on Premises		\$			

3. DO YOU SECURE RELEASES FROM ALL ENTRANTS – ATTACH A SAMPLE

Yes No

DOES NUMBER OF SPECTATORS EVER EXCEED 500 PER DAY

Yes No

4. DO YOU HAVE BLEACHERS OR GRANDSTANDS

Yes No

CONSTRUCTION

YEAR BUILT

SEATING CAPACITY – #

DO YOU MANAGE ANY HUNTS OR RACING EVENTS

Yes No

IF YES, WHAT TYPE

DO YOU OWN/USE/LEASE ANY HOUNDS FOR HUNTS

Yes No

HOW MANY HOUNDS

6. IF RODEOS ON PREMISE, DESCRIBE TYPE OF EVENTS

7. DO YOU ALLOW NON-BOARDERS TO USE YOUR FACILITIES – IF YES, PLEASE EXPLAIN

Yes No

GROSS RECEIPTS

\$

8. ALL OPERATIONS MUST BE DECLARED – DESCRIBE FULLY ANY OTHER EVENTS OR OPERATIONS NOT ALREADY MENTIONED IN THIS APPLICATION

9: Do you own a golf cart or ATV that is used off premises Yes No

Make/Model/Serial Number: _____ Value: \$ _____

NOTE: Coverage is not provided for injury to participants in horse races, rodeos, rodeo-type events, hunts, vaulting, and polo matches/practice.

GENERAL INFORMATION AND UNDERWRITING QUESTIONNAIRE

1. NUMBER OF YEARS AT THIS LOCATION

NUMBER OF YEARS EXPERIENCE IN THESE OPERATIONS

2. IF LESS THAN FIVE (5) YEARS, GIVE BRIEF DESCRIPTION OF EXPERIENCE AND BACKGROUND IN HORSE BUSINESS

3. DO YOU OBTAIN A RELEASE SIGNED BY BOARDERS AND STUDENTS RELIEVING YOU OF CLAIMS FOR BI & PD – IF YES, PLEASE ATTACH A COPY TO THIS APPLICATION

Yes No

4. DO YOU POST RULES

Yes No

DO YOU POST WARNING SIGNS

Yes No

DESCRIBE ANY SAFETY PROGRAM OR ATTACH INFORMATION

5. DESCRIBE TYPE OF ALL FENCING

6. DESCRIBE CONDITION

Excellent Good Fair Poor

HOW OFTEN IS FENCING CHECKED

PERSON TO CONTACT FOR INSPECTION

TELEPHONE NUMBER

()

REFER TO FRAUD WARNINGS ON PAGE 5 OF THE FARMOWNER APPLICATION

No coverage will be provided for any activity that is not fully disclosed on this application.

The undersigned hereby applies for insurance coverage as set forth in the application and affirms that the statements and representations made are to the best of his/her knowledge true.

APPLICANT'S SIGNATURE

X

DATE

/ /

AGENT'S SIGNATURE

X

DATE

/ /

Note: Farmowners and commercial liability policies generally exclude liability coverage for damage to non-owned property in the care, custody or control of the insured. Please complete a separate Care, Custody or Control application for the non-owned horses in your care. Your signature is requested below, if you are **declining** this coverage.

X

COVERAGE G – BLANKET FARM PERSONAL PROPERTY SUPPLEMENT TO THE FARMOWNER APPLICATION

NAME OF APPLICANT			POLICY/QUOTE NUMBER						
NOTE: Coverage cannot be bound without a completed inventory (Minimum limit \$15,000.)									
MACHINERY	UNIT PRICE	TOTAL VALUE	TOOLS & SUPPLIES	UNIT PRICE	TOTAL VALUE	LIVESTOCK	UNIT PRICE	TOTAL VALUE	
Tractor No. 1	\$	\$	Milk House Utensils & Sup.	\$	\$	Horses	\$	\$	
Tractor No. 2	\$	\$	Hog Feeders	\$	\$	Ponies	\$	\$	
Tractor No. 3	\$	\$	Hog Fountains	\$	\$	Sheep	\$	\$	
Tractor No. 4	\$	\$	Tank Heaters	\$	\$	Dairy Cows	\$	\$	
			Farrowing Crates	\$	\$	Heifers	\$	\$	
			Poultry Feeders	\$	\$	Beef Cows	\$	\$	
			Poultry Waterers	\$	\$	Beef Calves	\$	\$	
			Hen Nests	\$	\$	Bulls	\$	\$	
Crop Drier	\$	\$	Electric Motors	\$	\$	TOTAL LIVESTOCK			
Corn or Grain Head	\$	\$	Gas Engines	\$	\$	EQUESTRIAN EQUIPMENT		TOTAL VALUE	
Corn Picker	\$	\$	Fuel Tank and Stand	\$	\$	UNIT PRICE		TOTAL VALUE	
Corn Planter	\$	\$	Tractor Fuel	\$	\$				
Plows	\$	\$	Oil and Grease	\$	\$	Saddles	\$	\$	
Chisel Plow	\$	\$	Electric Welders	\$	\$	Show Saddles	\$	\$	
Vibratiller	\$	\$	Acetylene Welders	\$	\$	Bridles, Bits, Reins	\$	\$	
Disc	\$	\$	Spare Parts	\$	\$	Jog Carts, Bikes	\$	\$	
Quack Digger	\$	\$	Chain Saws	\$	\$	Buggies	\$	\$	
Harrows and Curl	\$	\$	Power Saws	\$	\$	Blankets, Hoods	\$	\$	
Cultipacker	\$	\$	Posthole digger	\$	\$	Sheets, Coolers	\$	\$	
Rotaryhoe and Truck	\$	\$	Electric Fencer	\$	\$	Grooming Equipment	\$	\$	
Rotatiller	\$	\$	Air Compressor	\$	\$	Halters, Lead Lines	\$	\$	
Cultivators	\$	\$	Wheel Barrows	\$	\$	Harnesses	\$	\$	
Drills and Seeders	\$	\$	Fertilizer	\$	\$	Tail Sets	\$	\$	
Fertilizer Spreaders	\$	\$	Spray Material	\$	\$	Jumping Equipment	\$	\$	
Manure Spreaders	\$	\$	Fans	\$	\$	Automatic Waterers	\$	\$	
Manure Loader	\$	\$	Building Material	\$	\$	Wood Shavings	\$	\$	
Stalk Cutters	\$	\$	Paint	\$	\$	Insect Control Equipment	\$	\$	
Weed Sprayer	\$	\$	Power Tools	\$	\$	Lounge Furniture	\$	\$	
Anhydrous Applier	\$	\$				Tack Trunks	\$	\$	
Corn Sheller	\$	\$				Tack Room (Portable)	\$	\$	
Grain Cleaner	\$	\$	Hand Tools (forks, shovels, brooms, hammers, saws, wrenches, rakes, etc., other misc. small tools)	\$	\$	Tack Room Accessories	\$	\$	
Silo Filler	\$	\$				Stable Banners	\$	\$	
Silo Unloader	\$	\$	Misc. Equipment (tarps, chains, parts, clippers, etc.)	\$	\$	Water Tanks	\$	\$	
Mowers	\$	\$				Whips, Whip Box	\$	\$	
Forage Harvester	\$	\$	TOTAL TOOLS AND SUPPLIES			\$	Misc. Tack	\$	\$
Hay Conditioner	\$	\$	GRAIN AND FEED		UNIT PRICE	TOTAL VALUE	Misc. Stable Equipment	\$	\$
Hay Crimper	\$	\$							
Hay Fluffer	\$	\$	Wheat	\$	\$	TOTAL EQUESTRIAN			
Hay Rake	\$	\$	Oats	\$	\$				
Hay Swather	\$	\$	Barley	\$	\$	SUMMARY			
Hay Baler	\$	\$	Corn	\$	\$	Total Value of Listed Items		\$	
Auger Wagons	\$	\$	Sealed Wheat Bushels	\$	\$	Other Unlisted Farm Personal Property		\$	
Chopper Wagons	\$	\$	Sealed Corn Bushels	\$	\$	Sub-Total		\$	
Wagons	\$	\$	Soybeans	\$	\$	Less Value of Excluded Property		\$	
Feed Trailers	\$	\$	Ground Feed	\$	\$	TOTAL VALUE		\$	
Feed Grinder	\$	\$	Hay (Bales or Tons)	\$	\$	Limit of Liability		\$	
Hammer Mill	\$	\$	Straw (Bales or Tons)	\$	\$				
Feed Mixer	\$	\$				AT TIME OF LOSS UNLESS SPECIFICALLY EXCLUDED IN THE POLICY, THE VALUE OF ALL FARM PERSONAL PROPERTY OWNED BY THE INSURED WILL BE INCLUDED TO ESTABLISH COMPLIANCE WITH THE CO-INSURANCE CLAUSE. EXCLUDED PROPERTY:			
Feed Carts	\$	\$							
Auger Elevators	\$	\$							
Portable Elevators	\$	\$							
Irrigation Equipment	\$	\$							
Power Lawn Mower	\$	\$							
TOTAL MACHINERY		\$	TOTAL GRAIN AND FEED		\$				

FIREPLACE, WOOD BURNING STOVE SUPPLEMENT

ATTACH PHOTO -- COMPLETE IN FULL

APPLICANT	POLICY/QUOTE NUMBER
-----------	---------------------

FIREPLACE INSERT COMPLETE QUESTIONS 1-6	FIREPLACE (BUILT-IN) COMPLETE QUESTIONS 1-4	FREE STANDING FIREPLACE &/OR STOVE COMPLETE QUESTIONS 1-6
--	--	--

1. TYPE OF HEATING EQUIPMENT

Built-In Fireplace Free Standing Fireplace Free Standing Stove
 Furnace Supplement Other: _____

2. IS THIS UNIT A MAJOR HEAT SOURCE FOR THE DWELLING

Yes No

3. WERE CHIMNEY AND EQUIPMENT INSTALLED BY CONTRACTOR NAME AND ADDRESS IF OTHER THAN THE HOME BUILDER

Yes No

4. CHIMNEY INFORMATION – TYPE OF CHIMNEY

Masonry with tile flue liner Prefab'd metal chimney (UL approved)
 Other _____

WHEN WAS CHIMNEY LAST CLEANED HOW OFTEN IS CHIMNEY CLEANED

CLEANED BY WHOM

Insured Chimney Sweep* Contractor*

*NAME AND ADDRESS

IS MORE THAN ONE UNIT VENTED INTO THE SAME CHIMNEY FLUE

Yes No

THE FOLLOWING QUESTIONS SHOULD BE ANSWERED FOR FREE STANDING FIREPLACES AND/OR STOVES.

BRAND NAME	YEAR PURCHASED
------------	----------------

5. DOES YOUR FREE STANDING HEATING UNIT HAVE THE MINIMUM CLEARANCES OF:

Yes No 36" between the stove box and any unprotected combustible surface in all directions
 Yes No 4" between stove and floor
 Yes No Pad under stove (see diagrams below)

6. STOVE PIPE INFORMATION – DIAMETER OF PIPE DISTANCE FROM THE NEAREST COMBUSTIBLE SURFACE

ARE PIPE SECTIONS OR JOINTS FASTENED WITH METAL SCREWS	DOES THE PIPE PASS THROUGH FLOOR, WALLS OR CEILINGS
<input type="checkbox"/> Yes <input type="checkbox"/> No	<input type="checkbox"/> Yes <input type="checkbox"/> No

IF SO, IS IT PROTECTED WITH A

Ventilated thimble Fuel connector Fire stop spacer

IS MORE THAN ONE UNIT VENTED INTO THE SAME CHIMNEY

Yes No

DATE	INSURED'S SIGNATURE
/ /	X

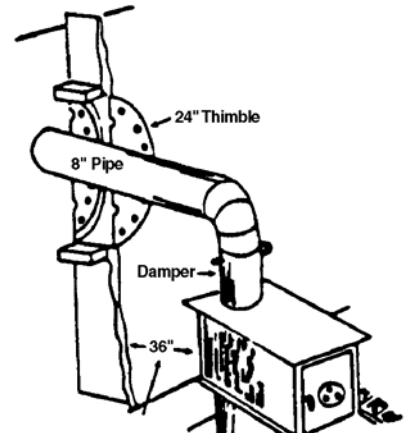
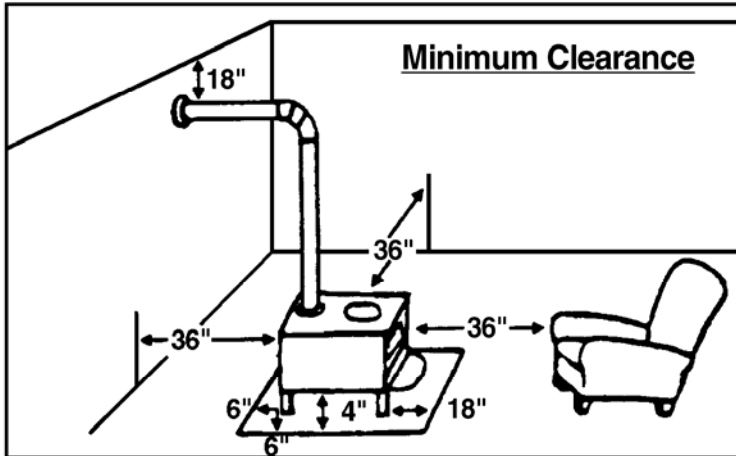

THESE CLEARANCES CAN BE REDUCED IF YOUR FLOOR OR COMBUSTIBLE WALL IS PROTECTED BY BRICKS WITH MORTAR OR BY METAL COVERED ASBESTOS STOVE BOARD. THE PAD UNDER YOUR STOVE SHOULD EXTEND 18" BEYOND THE ASH REMOVAL DOOR OR YOUR STOVE.

COLLAPSE COVERAGE SUPPLEMENT

NAMED INSURED/APPLICANT	POLICY NUMBER
-------------------------	---------------

ANSWER ALL QUESTIONS TO THE BEST OF YOUR ABILITY

	LOC # _____	LOC # _____	LOC # _____	LOC # _____
	BLDG # _____	BLDG # _____	BLDG # _____	BLDG # _____
CIRCLE ONE				
1. Does any part of the structure (i.e., door frames or window frames) indicate foundation settling?	Y N	Y N	Y N	Y N
2. Is the roof ridge line straight, indicating sidewalls have not spread?	Y N	Y N	Y N	Y N
3. Are the windowsills firmly anchored showing no signs of deterioration?	Y N	Y N	Y N	Y N
4. To the best of your knowledge, does the total design load meet or exceed local building codes? Explain any "no" answer in Comments below.	Y N	Y N	Y N	Y N
5. Who built the building/structure? (I = Insured; C = Contractor)	I C	I C	I C	I C
6. Is building fully enclosed, no open sheds attached?	Y N	Y N	Y N	Y N
7. Is proper roof drainage supplied?	Y N	Y N	Y N	Y N
8. What is the approximate pitch of the roof?				
9. Is weed/brush growth around the building properly controlled?	Y N	Y N	Y N	Y N
10. If the building is on a concrete block foundation, does an inspection reveal cracks and/or separation?	Y N	Y N	Y N	Y N
11. In your estimation, is the quality of construction: (Average = A; Below Average = BA; or Above Average = AA)	A BA AA	A BA AA	A BA AA	A BA AA
12. Describe any special precautions that are taken during severe snow and ice storms: _____ _____ _____ _____				
13. Comments: _____ _____ _____ _____				
INSPECTED BY (NAME)	DATE			
<input type="checkbox"/> Agent <input type="checkbox"/> Engineer <input type="checkbox"/> Company Representative <input type="checkbox"/> Other _____				

AMERICAN BANKERS INSURANCE COMPANY OF FLORIDA

APPLICATION FOR LEGAL LIABILITY OF NON-OWNED HORSES IN YOUR CARE, CUSTODY OR CONTROL

Agency Name Plamp-Keen Agency, Inc		
Mailing Address PO Box 5039, Louisville, KY 40255-0039		E-Mail Address debi@plampkeen.com
Telephone No. (800) 626-2494 or (502) 451-7700	Fax No. (502) 458-7416	Agency Code: 3157001

This is NOT a Binder

<input type="checkbox"/> Direct Bill	<input type="checkbox"/> New Business – Desired Effective Date _____
<input type="checkbox"/> Account Current	<input type="checkbox"/> Renewal – Expiration Date _____ Policy No: CCC _____

IMPORTANT: INCOMPLETE AND UNSIGNED APPLICATIONS WILL BE RETURNED FOR COMPLETION

Name of Insured	Business / Stable Name	
Mailing Address		
City / State / Zip Code		
Telephone Number Home / Stable or Business	Fax Number	Email Address
Location of actual operations if other than mailing address		
If a corporation, list all officers and directors. If a partnership, list all partners		

A SEPARATE APPLICATION FOR THE INFORMATION THAT FOLLOWS WILL BE REQUIRED FOR EACH LOCATION

Do You: <input type="checkbox"/> Own <input type="checkbox"/> Lease or <input type="checkbox"/> Rent The premises ?	How long has the insured or manager been in this business? _____ years. If less than three years, briefly describe related experience. _____ _____
If leased/ rented, who is responsible for the fence repair? _____ If leased / rented, who is responsible for building repair? _____ Describe type of fencing used in runs, pastures, paddocks: _____ Describe condition of fencing: <input type="checkbox"/> Excellent <input type="checkbox"/> Good <input type="checkbox"/> Fair <input type="checkbox"/> Poor Describe condition of stables: <input type="checkbox"/> Excellent <input type="checkbox"/> Good <input type="checkbox"/> Fair <input type="checkbox"/> Poor Operations: <input type="checkbox"/> Stable Owner <input type="checkbox"/> Boarding <input type="checkbox"/> Breeding <input type="checkbox"/> Training <input type="checkbox"/> Other _____ (Check all that apply)	
Breed of animals: _____ Use of animals: _____ Describe type of security / supervision of stables _____	
Are fire extinguishers accessible and operable in each stable? <input type="checkbox"/> Yes <input type="checkbox"/> No Is any stable over 25 years old? <input type="checkbox"/> Yes <input type="checkbox"/> No If yes, when was the last time electrical wiring was checked, certified safe, and suitable for current usage? _____	

Care, Custody or Control

Number of Stalls: Barn #1 _____ Barn #2 _____ Barn #3 _____ Barn #4 _____

Minimum number of non-owned horses _____ Minimum value of non-owned horses _____

Average number of non-owned horses _____ Average value of non-owned horses _____

Maximum number of non-owned horses _____ Maximum value of non-owned horses _____

POLICY COVERS INCIDENTAL TRANSPORTATION ONLY, UP TO 150 MILES FROM THE INSURED'S LOCATION.
COVERAGE MAY BE EXTENDED. REFER TO UNDERWRITER FOR PREMIUM.

Do you transport horses for others? Yes No If yes, maximum number of trips per year _____

Maximum number of animals per trip _____ Radius of normal operations _____ miles

Number of trips and destinations exceeding normal 150 mile radius _____

Describe any losses or potential claims in the past three years and include deaths of any animal(s) in your custody, even if claim was not presented:

Fraud Notices

Standard: Any person who knowingly and with intent to defraud any insurance company or other person files an application for insurance or statement of claim containing any materially false information or conceals, for the purpose of misleading, information concerning any fact material thereto, commits a fraudulent act, which is a crime, and may subject such person to criminal and civil penalties.

Florida Applicants: Any person who knowingly and with intent to injure, defraud, or deceive any insurer, files a statement of claim or an application containing any false, incomplete, or misleading information is guilty of a felony of the third degree.

New Jersey Applicants: Any person who includes false or misleading information on an application for an insurance policy is subject to criminal and civil penalties.

Name of Application (please print)

Signature of Applicant:

Date

Agent Signature

Date

I understand that the insurance being applied for, if accepted by the Company, will be based on the statements made in this application. If information is withheld or falsely stated, any insurance issued may be subject to rescission or modification as provided by the law of the state in which the application was accepted or the policy issued.

AMERICAN BANKERS INSURANCE COMPANY OF FLORIDA

LEGAL LIABILITY – CATE, CUSTODY AND CONTROL PROGRAM PREMIUM RATING RULES AND GUIDELINES

Premium for the limits chosen will be rated on the average number of horses in the care of the insured or the total number of horses stabled in any one barn, whichever is greater.

Rating on this policy for the limits of liability chosen includes incidental transit, which is generally defined as 6 trips of 150 miles or less, per year, carrying 1 or 2 non-owned horses. If our Transportation Extension Endorsement is used the 150-mile radius restriction is removed and changes it to an Unlimited Radius for an additional premium of \$100 annually.

RATES & LIMITS OF LIABILITY

Limit per Horse	Maximum loss per year	Policy premium for up to 8 horses	Add'l \$ each horse over 8
<input type="checkbox"/> \$2,500	\$25,000	\$150.00	\$8.00
<input type="checkbox"/> \$5,000	\$25,000	\$150.00	\$10.00
<input type="checkbox"/> \$5,000	\$50,000	\$200.00	\$10.00
<input type="checkbox"/> \$10,000	\$50,000	\$225.00	\$12.00
<input type="checkbox"/> \$10,000	\$100,000	\$250.00	\$15.00
<input type="checkbox"/> \$15,000	\$150,000	\$300.00	\$18.00
<input type="checkbox"/> \$25,000	\$250,000	\$350.00	\$20.00
<input type="checkbox"/> \$50,000	\$250,000	\$550.00	\$25.00
<input type="checkbox"/> \$75,000	\$300,000	\$650.00	\$30.00
<input type="checkbox"/> \$100,000	\$300,000	\$700.00	\$35.00
<input type="checkbox"/> \$150,000	\$400,000	\$1,050.00	\$55.00
<input type="checkbox"/> \$200,000	\$400,000	\$1,150.00	\$75.00
<input type="checkbox"/> \$500,000	\$1,000,000	\$1,500.00	\$95.00

NEW BUSINESS
 RENEWAL BUSINESS
Previous Policy Number:

POLICY EFFECTIVE:
From: _____ 20____
To: _____ 20____

**APPLICATION FOR THE
Farm Umbrella Policy**

Coverage is not bound by completion of this application.

I. GENERAL INFORMATION							
A.	APPLICANT'S NAME	AGENCY NAME Plamp-Keen Agency, Inc.					
	ADDRESS	ADDRESS PO Box 5039					
	CITY/STATE/ZIP CODE	CITY/STATE/ZIP CODE Louisville, KY 40255-0039				AGENCY CODE NO. 3157001	
	TELEPHONE NUMBER ()	TELEPHONE NUMBER (800) 626-2494			FAX NUMBER (502) 458-7416		
B.	THE APPLICANT IS: <input type="checkbox"/> An Individual <input type="checkbox"/> A Corporation <input type="checkbox"/> A Partnership <input type="checkbox"/> Other (Describe)						
	ARE ANY COVERED DRIVERS 18 YEARS OR YOUNGER		IF YES, HOW MANY		RELATIONSHIP TO APPLICANT		
	<input type="checkbox"/> YES <input type="checkbox"/> NO						
	REQUESTED LIMIT OF LIABILITY <input type="checkbox"/> \$1,000,000 <input type="checkbox"/> \$2,000,000 <input type="checkbox"/> \$3,000,000 <input type="checkbox"/> \$4,000,000 <input type="checkbox"/> \$5,000,000 <input type="checkbox"/> \$ 5,000 Retained Limit						
II. AUTOMOBILE – DESCRIBE ALL AUTOMOBILES AND MOTORCYCLES. DO NOT INCLUDE FARM MACHINERY.							
TYPE	SIZE CLASS	OWNED BY APPLICANT	LEASED TO APPLICANT	TOTAL NUMBER UNITS	USE	OPERATING RADIUS	CARGO CARRIED
PRIVATE PASSENGER	AUTOS						
LIGHT TRUCKS	PICK-UPS						
FARM SERVICE CLASS TRUCKS	MEDIUM						
	HEAVY						
	EXTRA HEAVY						
FARM TRUCK/TRACTOR	HEAVY						
	EXTRA HEAVY						
III. DESCRIBE THE EXPOSURES AT THE VARIOUS INSURED LOCATIONS. IF NO EXPOSURE EXISTS, STATE "NONE."							
A.	DWELLINGS OCCUPIED BY INSUREDS Number _____						
B.	TOTAL NUMBER OF ACRES OPERATED (ALL LOCATIONS) Number _____						
C.	DWELLINGS RENTED TO OTHERS Number _____						
D.	RECREATIONAL MOTOR VEHICLES (NOT LICENSED FOR ROAD USE) Number _____						
E.	WATERCRAFT – NUMBER AND TYPE OF OWNED, LEASED OR CHARTERED WATERCRAFT:						
	NO.	TYPE	H.P.	SPEED (M.P.H.)	OVERALL LENGTH	WHERE USED	
	CARRIER	POLICY NUMBER		POLICY PERIOD	COVERAGE	LIMITS OF LIABILITY	PREMIUM
IV. DOES THE APPLICANT HAVE ANY OF THE FOLLOWING EXPOSURES? IF "YES," EXPLAIN BELOW. INCLUDE IN THE EXPLANATION A DESCRIPTION OF THE PRIMARY INSURANCE COVERAGE.							
		EXPOSURE		IS THERE PRIMARY COVERAGE?		IS UMBRELLA COVERAGE DESIRED?	
		YES	NO	YES	NO	YES	NO
A.	Custom farming receipts in excess of \$2,000/year						
B.	Office, professional, private school or studio occupancy						
C.	Farm employees						
D.	Farm operations includes "livestock"						
E.	Seed sales						

OTHER EXPOSURES

F. DOES THE APPLICANT EVER HIRE THE SERVICES OF OTHERS (INCLUDING CUSTOM FARMING OR CROP DUSTING)?
 Yes No If "Yes," Explain.
 ARE CERTIFICATES OF INSURANCE REQUIRED OF ALL SUB OR INDEPENDENT CONTRACTORS?
 Yes No If "Yes," describe required coverage and limits of liability

G. DOES THE APPLICANT HAVE ANY OWNED OR LEASED AIRCRAFT?
 Yes No

H. DOES THE APPLICANT LEASE, RENT OR USE ANY PROPERTY OF OTHERS?
 Yes No If "Yes," Explain.
 IF MORE THAN ONE ENTITY IS INCLUDED IN THIS APPLICATION, DOES ONE ENTITY LEASE, RENT OR USE PROPERTY TITLED IN THE NAME OF ANOTHER ENTITY?
 Yes No If "Yes," Explain.
 IS ANY PROPERTY LEASED, RENTED OR LOANED TO THE APPLICANT WHICH BELONGS TO DIRECTORS OR OFFICERS OF THE APPLICANT?
 Yes No If "Yes," Explain.

I. LOSSES OVER \$10,000 – IF NO LOSSES, STATE "NONE."

DATE OF LOSS	DESCRIPTION OF LOSS	B.I. OR P.D.	NUMBER OF CLAIMANTS	AMOUNT PAID	AMOUNT OUTSTANDING

V. DRIVER'S INFORMATION

NAME (AS IT APPEARS ON LICENSE)	DATE OF BIRTH	DRIVER'S LICENSE NUMBER	STATE

VI. PRIMARY INSURANCE – LIST ALL PRIMARY LIABILITY AND WORKERS' COMPENSATION POLICIES BELOW. DESCRIBE COVERAGE ACCURATELY.

TYPE OF POLICY AND COVERAGE	INSURER	LIMITS OF LIABILITY
1. Standard Workers' Compensation and Employers' Liability	Insurer: _____ Policy Number: _____ Policy Period: _____	Statutory Workers' Compensation \$ _____
2. Automobile Liability <input type="checkbox"/> a. Personal Automobiles	Insurer: _____ Policy Number: _____ Policy Period: _____	Bodily Injury \$ _____ Each Person \$ _____ Each Occurrence Property Damage \$ _____ Each Occurrence Uninsured Motorists _____
<input type="checkbox"/> b. Commercial Automobiles <input type="checkbox"/> Basic Coverage <input type="checkbox"/> Comprehensive Coverage <input type="checkbox"/> Nonowned Automobiles <input type="checkbox"/> Hired Automobiles	Insurer: _____ Policy Number: _____ Policy Period: _____	Bodily Injury \$ _____ Each Person \$ _____ Each Occurrence Property Damage \$ _____ Each Occurrence Uninsured Motorists _____
3. General Liability <input type="checkbox"/> Farmer's Comp. Personal Liability <input type="checkbox"/> Comprehensive General Liability <input type="checkbox"/> Personal Injury <input type="checkbox"/> Recreational Motor Vehicles <input type="checkbox"/> Custom Farming <input type="checkbox"/> Injury to Farm Employees <input type="checkbox"/> Other (Describe)	Insurer: _____ Policy Number: _____ Policy Period: _____	\$ _____ Each Occurrence \$ _____ Aggregate

STANDARD FRAUD WARNING: Any person who knowingly and with intent to defraud any insurance company or other person files an application for insurance or statement of claim containing any materially false information or conceals, for the purpose of misleading, information concerning any fact material thereto, commits a fraudulent insurance act, which is a crime, and may subject such person to criminal and substantial civil penalties. (This wording does not apply in Oregon.)

- FLORIDA:** Any person who knowingly and with intent to injure, defraud, or deceive any insurer files a statement of claim or an application containing any false, incomplete, or misleading information is guilty of a felony of the third degree.
- NEW JERSEY:** Any person who includes any false or misleading information on an application for an insurance policy is guilty of insurance fraud and is subject to criminal and civil penalties.
- VIRGINIA:** It is a crime to knowingly provide false, incomplete, or misleading information to an insurance company for the purpose of defrauding the company. Penalties include imprisonment, fines, and denial of insurance benefits.

The undersigned hereby applies for insurance coverage as set forth in the application and affirms that the statements and representations made are to the best of his/her knowledge true.

THIS APPLICANT REPRESENTS THAT THE ABOVE STATEMENTS AND FACTS ARE TRUE AND THAT NO MATERIAL FACTS HAVE BEEN SUPPRESSED OR MISSTATED.

DATE / /	APPLICANT X
-------------	-----------------------

REMARKS	

DATE / /	AGENT'S SIGNATURE X
-------------	-------------------------------

MOBILE HOME QUESTIONNAIRE

POLICY NO.

NAMED INSURED: _____

AGENCY: _____

LOCATION #: _____ DATE: _____

HOME INFORMATION

Manufacture: _____ Length _____ Width _____ Model Year _____

Purchase Date: _____ Purchase Amount \$ _____ Mobile was purchased New Used

How much would it cost to replace the home with a similarly equipped new home? \$ _____

Does the insured own the mobile home? Yes No

Mortgagee: _____

Does the insured live in the mobile home? Yes No. If no, who lives in the mobile home? _____

Is the mobile home seasonable? Yes No

Is the mobile home on a permanent foundation? Yes No

What type of siding does the mobile home have? Hardwood Aluminum Vinyl Other

Does the mobile home have a woodburning stove? Yes No

If yes, attach Woodburning Stove Supplement and picture of woodburning stove.

Is a current picture of the mobile home on file with American Reliable Insurance Company? Yes No

If no, please attach a picture.

Complete information below if this is a new submission:

Current Insurance Company: _____

Current Policy Number: _____

Current Policy Expires: _____

Past three-year losses on mobile home: _____

Authorized Agent: _____ Date: _____

Agency: _____

Agency Code: _____

CAMP SUPPLEMENT

If none, check here.

Named Insured: _____ Policy No. If Renewal _____

1. The camp is operated from _____ to _____. Camp Receipts _____
Month/Date Month/Date
2. The hours of the camp are from _____ to _____, _____ days per week.
3. Are overnight accommodations provided? Y N
4. Are meals prepared and/or provided by you? Y N
5. Ages of campers? _____.
6. Are there any campers who are physically or emotionally handicapped? Y N
7. Number of campers per day per week. _____/_____.
8. Number of campers that are not regular students per day per week _____/_____.
9. Number of adult supervisors? _____
10. There are _____ supervisors under the age of 18.
11. What are the ages of the counselors? _____. What type of training do they receive?

12. Is any camp counselor/employee/supervisor under investigation for, or has a previous record of, child abuse? Y N
13. How are medications kept and distributed to children with prescription/non-prescription needs? Y N
14. Campers are under adult supervision at all times. If children are not in the direct vision of adults, are adults aware of where they are and what they are doing? Y N
15. All equipment and buildings are maintained in a safe, clean condition and in good repair. Indoor and outdoor environments are safe, clean and spacious. Y N

16. Is there a swimming pool? Y N If the answer is yes, answer the following.

Is the pool fenced? Y N Depth _____ Is there a diving board? Y N

Is there a lifeguard on duty? Y N

What type of certification is required of the lifeguard? _____

Are swimming lessons given? Y N

What type of certification is required of the instructor? _____

17. There are _____ fire extinguishers in the buildings in which the campers will be conducting activities.

18. All poisonous/toxic materials are kept under lock and key and out of children's reach. Y N

19. Detail all camp activities _____

20. Are there any off premises activities? Y N

If yes, describe in detail _____

21. Do you provide transportation to campers for any reason? Y N

If yes, we will require a COI from your auto carrier and complete driver information of all drivers.